

S5 - Window



Outside view



Inside view

Exterior frame

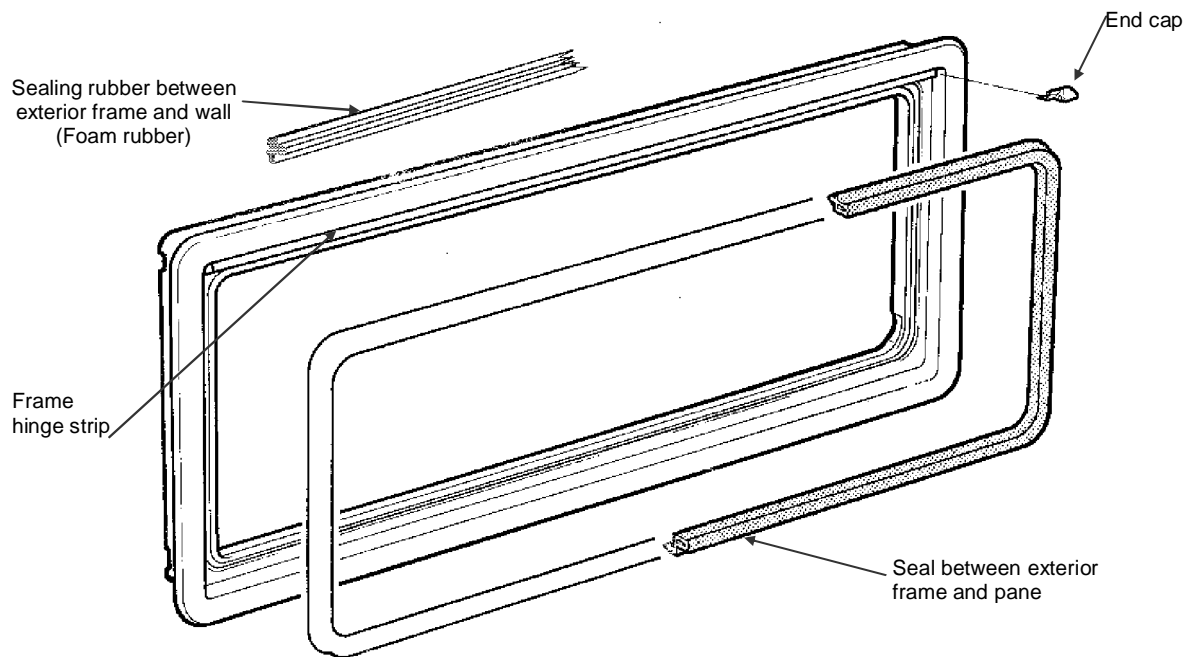

PROBLEM:

Replacement of the exterior frame
Replacement of the sealing rubber
Replacement of the end cap

Replacement of the exterior frame

For dismantling the exterior frame remove the ventilation grating of the interior frame first and then loosen all screws from the interior frame.

Caution !: Before the screwed connections of the exterior frame are loosened, it must be ensured that the window is secured from outside against falling out.

Carefully remove the interior frame and exterior frame completely, beginning at a corner of the partition wall of vehicle. Before the insertion of the new exterior frame, the sealing surface of the wall section is to be cleaned. With the installation, a suitable caulking material must be employed. Permanently-plastic sealant mass (bead \varnothing 6-8mm) is applied all round in the corner of the frame to seal the exterior frame. From inside, the exterior and interior frames are screwed together with each other, where it is to be ensured that the screws are not tightened too much (max. tightening torque 3 Nm).

Replacement of the sealing rubber

Remove sealing rubber from the slot

Caution!: Bond at the corners and at the joint with superglue..



Remove adhesive residue with the aid of a small screwdriver. While inserting the new sealing rubber, it is to be ensured that the joint of the rubber seats centrally below. In order to stabilize the rubber, it is required to fix the corners and the joint with superglue.

Replacement of the end cap



If the end cap has broken-off, there is a possibility of replacing it. For this, it is necessary to disconnect the rear leg of the flush end cap. Bond front side and leg to the frame hinge with the aid of superglue.

Interior frame

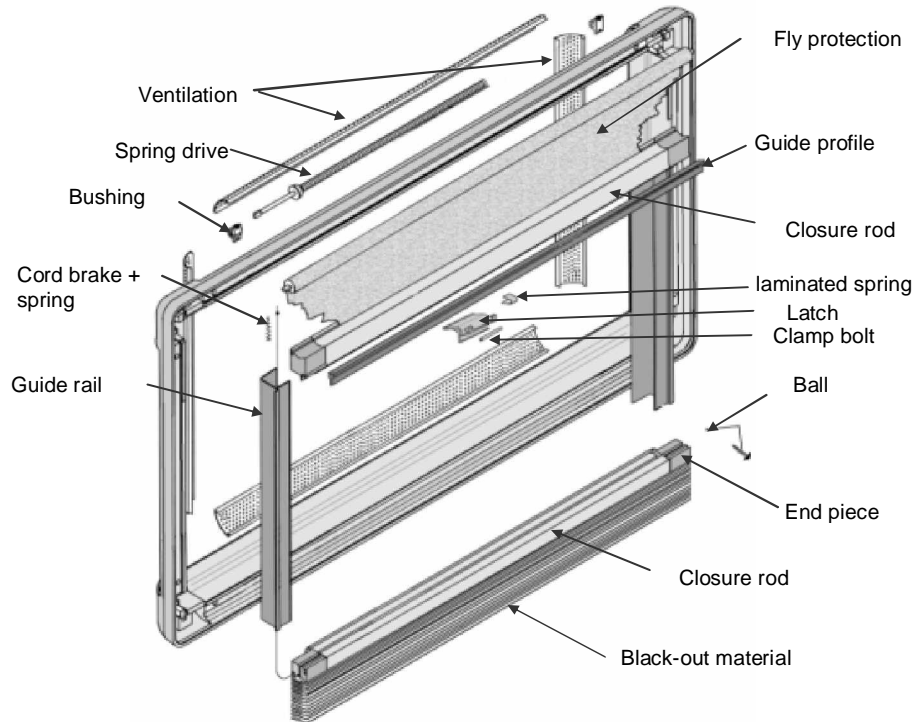

PROBLEM :

Replacement of the complete interior frame
 Replacement of the fly protection window blind
 Replacement of the shade roller blind
 Replacement of the spring drive motor
 Replacement of the close-off

Replacement of the complete interior frame



Loosen and pull out ventilation section profile with the aid of a screwdriver at the side through lifting. Loosen screws and remove interior frame. Before the loosening the last screw, it is to be ensured that the exterior frames with windowpane cannot fall out. Installation implemented in reverse order. The tightening torque of 3 Nm is to be considered.

Replacement of the fly protection window blind

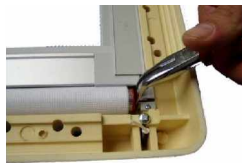

Loosen spring drive motor from receptacle frame with the aid of pointed pliers.

Caution !: Spring is under stress. Danger of injury!



The window blind can then be removed by tilting the closure rod from the interior frame. The installation is implemented in reverse order, considering the clamping bar.

Clamping bar: Tube length in mm/100 +3= rotation of the spring drive motor shaft

Example: Tube length =1000mm $1000\text{mm}/100+3= 13$ that is: 13 rotations clockwise

Replacement of the shade roller blind



The shade roller blind is a cord-guided window blind. For the dismantling of the window blind the stress in the cord-pull brake must be relieved. Loosen all four cross-slotted screws at the corners completely.

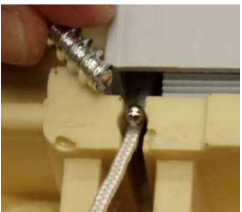

Caution !: Under the two cross-slotted screws on the black-out side is located a steel ball in each case. This must not be lost since it is required for the stressing.



The remove the stapler clip from the bracket profile of the frame with a suitable screwdriver.



Take the window blind from guide channel by slight tilting. Mounting of new fold-curtain roller blind in reverse order.

Caution !: In fixing the window blind it is to be ensured that the cord with spring is installed above (on the fly protection window blind) without steel ball, so that the spring effect is guaranteed.

Tighten window blind cords in parallel, i.e. springs at the upper end must be half tensed. Release one cord and securely tightening the held one with the aid of the cross-slotted screw and steel ball. Fix second cord then under the same stress. The roller blind run can be adjusted by tighter fixing of the cords. Carrying out sample closures after installation has been implemented and paying attention to right-angled closing of the closure rods with respect to the interior frame. Where appropriate, readjust.

Replacement of the spring drive motor



Release interior frames as described under replacement of the complete interior frame. Then remove window blind as described under replacement of the fly protection. Pull out the spring drive motor sideways and mount new part in reverse order.

Caution !: Note clamping bar

Clamping bar: Tube length in mm/100 +3= rotation of the spring drive motor shaft

Example: Tube length =1000mm 1000mm/100+3= 13 that is: 13 rotations clockwise

Replacement of the close-off



Dismantling of the complete interior frame, as described under replacement of the complete interior frame. Then take out the fly protection window blind as described under replacement of the fly protection window blind.

Removing side end cap from the single-sided closure rod with the aid of a plastic hammer.



To remove the old part, insert screwdriver into slot and knock out sideways over the center point. With the insertion of the new part, it is to be ensured that the leaf spring is inserted together with the close-off. Subsequent assembling of the leaf spring is possible only under complicated conditions.

Windowpane

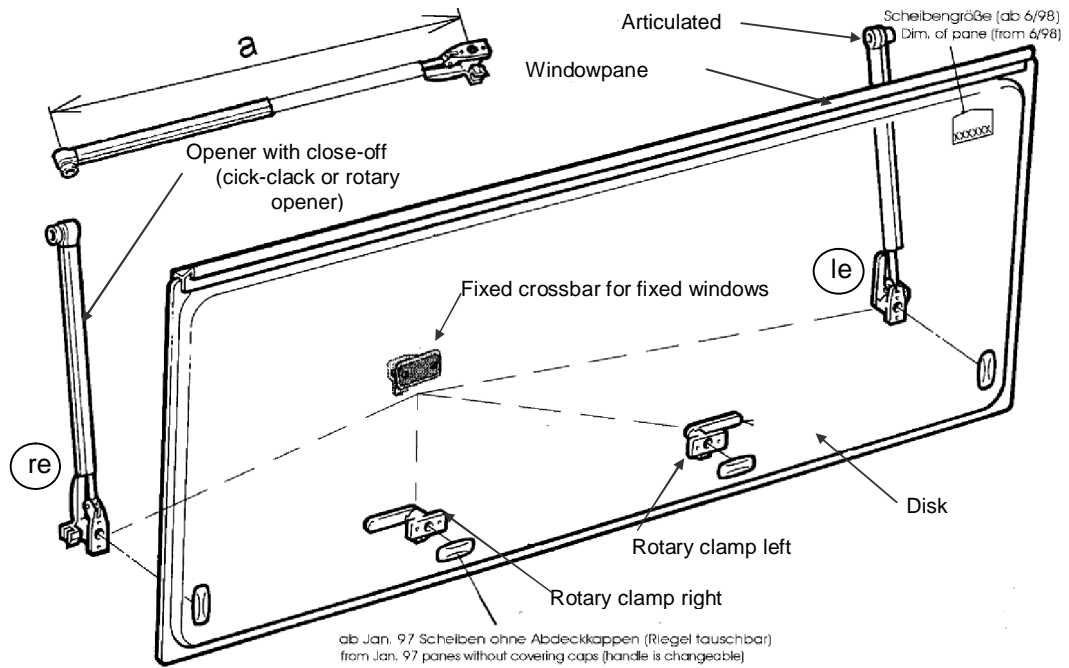

PROBLEM:

Windowpane replacement
 Replacement of the opener
 Replacement of the rotary clamps

Windowpane replacement



Loosen the cross-slotted screws at the side articulated supports of the opener. Unlock pane on the lock.

Caution !: With opening the windowpane through 90° it releases itself from the frame hinge and falls out.



With fixing in a new acrylic pane, it must be ensured that the windowpane hinge is positioned properly in the frame hinge. With fixing the windowpane, the fitting angle must be $>90^\circ$, so that the windowpane hinge can be inserted into the frame hinge. Before closing, ensure freedom of movement in order to avoid possible damage in the hinge area. Then close window and fasten opener to the frame.

Replacement of the opener

In order to replace the opener, open window pane by approx. 45°. Then clip off the opener from the opener receptacle (rotary clamp). Dismantle openers at the articulated lug of the exterior frame. Mount the spare part in reverse order again.

Replacement of the rotary clamp

Loosen rotary clamp at the fixing screws and install new part in reverse order.