

## Kombi-Cassette-Blind

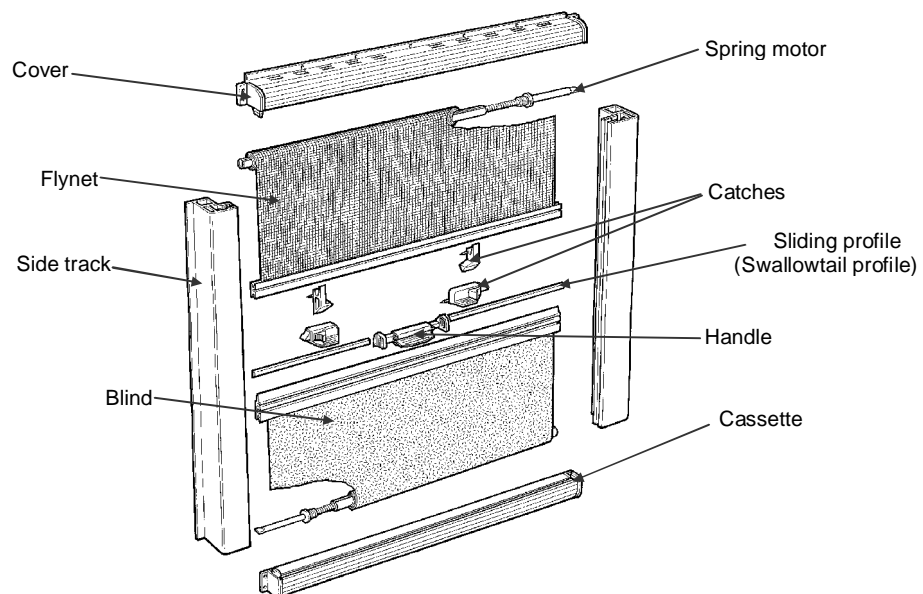

### PROBLEM DESCRIPTION :

Defective spring motor

Exchanging blind or flynet

Defective handle

### Defective spring motor

In order to exchange the spring motor unscrew the side covers of the cassette. Take care to unscrew the side on which the spring motor is mounted (see exploded view on page 1).

**Achtung!** Attention! Risk of injury resulting from the spring jumping out or recoiling uncontrollably. In these blinds the spring motor is tensioned with the cassette cover.

After removing the cassette cap remove the rollo and pull the spring motor out of the grooved tube. Insert new spring motor and assemble in reverse order, taking care that the Rollos are held tensioned by the cassette covers.

Winding rule: Tube length in mm/100 +3= revolutions of the spring shaft

Example: Tube length =1000mm 1000mm/100+3= 13 i.e.13 revolutions in a clockwise direction

### Exchanging blind or flynet

In order to change the rollos unscrew the cassette cover as described in defective spring motor, disassemble the rollo completely from the cassette and assemble the new part in reverse order. Wind spring motor according to the winding rule

### Defective Handle



Disassemble rollos as described under defective spring motor. Swallowtail profile can be removed from the end bar by lifting the side buttons. Re-assemble in reverse order



Remove handle from the recessed rest position by pushing it sideways with a plastic hammer. Assemble in reverse order.

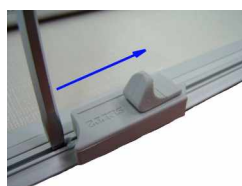

The catches can be removed from the recessed rest position by pushing sideways with a plastic hammer as well.